

INDEX

Section	Page
<u>Operational Amplifiers</u>	2
<u>Operational Amplifier Sample Problems</u>	6
<u>Diodes</u>	13

ELECTRONICS

Electronic circuits may contain combinations of passive and active elements, and these may be linear or nonlinear devices. Many electronic elements are semiconductors, which are inherently nonlinear. While the curves are nonlinear, performance within a limited range may be assumed to be linear if the variations in incoming small signals are much less than the average (steady, DC, etc.) values. Amplifier operation is normally in the linear active region, but operation in other regions is possible for some applications.

Operational Amplifiers

An amplifier produces an output signal from the input signal. The input and output signals can be either voltage or current. The output can be either smaller or larger (usually larger) than the input in magnitude. In a linear amplifier, the input and output signals usually have the same waveform but may have a phase difference that could be as much as 180 degrees. For instance, an inverting amplifier is one for which $v_{out} = -A_v v_{in}$. For a sinusoidal input, this is equivalent to a phase shift of 180 degrees.

The ratio of the amplitude of the output signal to the amplitude of the input is known as the gain or amplification factor, A : A_v if the input and output are voltages, and A_i if they are currents.

An operational amplifier (op amp) is a high-gain DC amplifier that multiplies the difference in input voltages. The equivalent circuit of an op amp is shown in Fig. 1.

$$v_o = A_v (v_{in+} - v_{in-}) \quad [1]$$

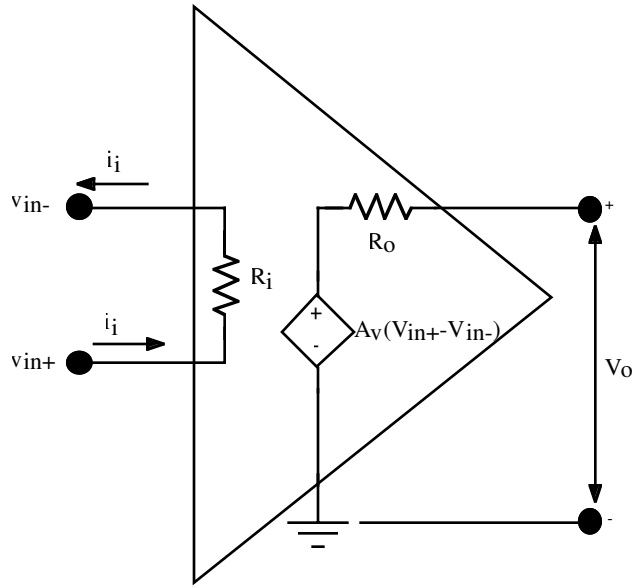
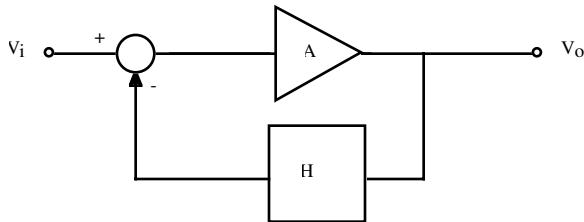

Figure 1. Equivalent Circuit for an Ideal Operational Amplifier

$$\frac{V_o}{V_i} = \frac{A}{1 + AH}$$



(a) feedback system

$$\frac{V_o}{V_i} = -\frac{R_f}{R_i}$$

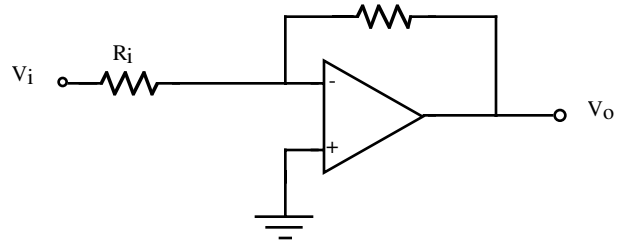

(b) inverting amplifier

$$\frac{V_o}{V_i} = \frac{R_f + R_i}{R_i}$$

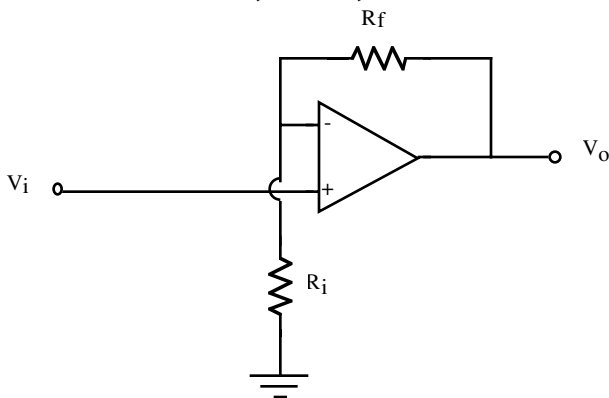

(c) non-inverting amplifier

$$V_o = -R_f \left(\frac{V_1}{R_1} + \frac{V_2}{R_2} + \frac{V_3}{R_3} \right)$$

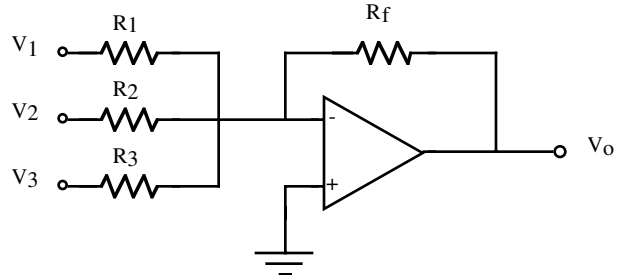

(d) summing amplifier

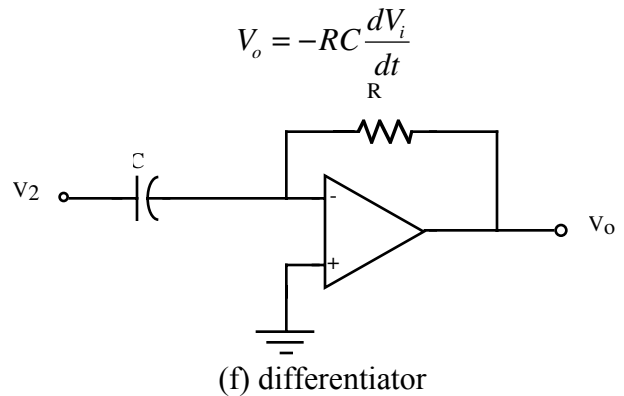
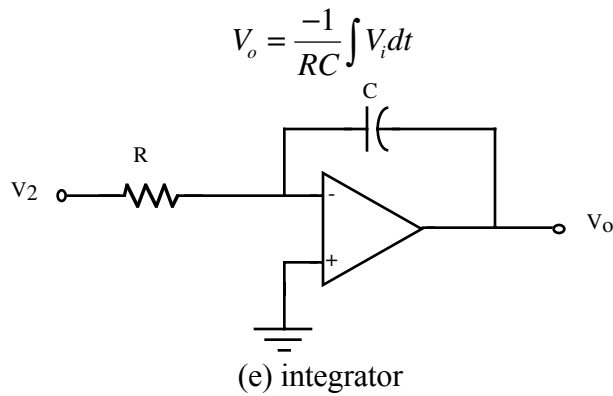

$$\frac{V_o}{V_i} = \frac{-R_f}{R_i(1 + j\omega R_f C)} \text{ [sinusoidal input]}$$

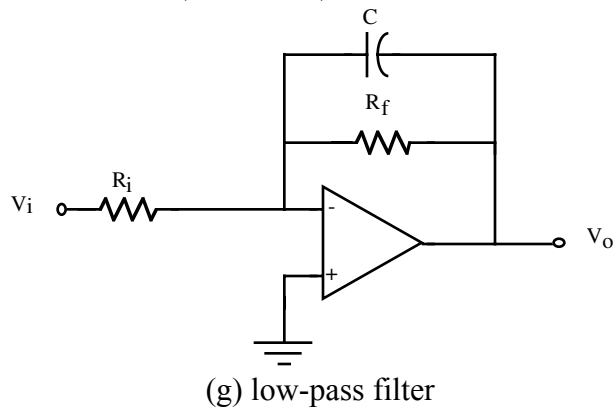

Table 4.1 Operational Amplifier Circuits

The characteristics of an ideal op amp are infinite positive gain, A_v , infinite input impedance, R_i , zero output impedance, R_o , and infinite bandwidth. (Infinite bandwidth means that the gain is constant for all frequencies down to 0 Hz.) Since the input impedance is infinite, ideal op amps draw no current. An op amp has two input terminals—an inverting terminal marked “-” and a non-inverting terminal marked “+”. From Eq. [1],

$$\frac{v_o}{A_v} = (v_{in+} - v_{in-}) \quad [2]$$

As the gain is considered infinite in an op amp,,

$$\frac{v_o}{A_v} = 0 \quad [3]$$

Combining Eqs. [2] and [3],

$$v_{in+} - v_{in-} = 0 \quad [4]$$

$$v_{in+} = v_{in-} \quad [5]$$

This is called a virtual short circuit, which means that, in an ideal op amp, the inverting and non-inverting terminals are at the same voltage. The virtual short circuit, and the fact that with infinite input impedance the input current i_i is zero, simplify the analysis of op amp circuits.

With real op amps, the gain is not infinite but is nevertheless very large (i.e., $A_V = 10^5$ to 10^8). If V_{in+} and V_{in-} are forced to be different, then by Eq. [1] the output will tend to be very large, saturating the op amp at around ± 10 - 15 V.

The input impedance of an op amp circuit is the ratio of the applied voltage to current drawn (v_{in}/i_{in}). In practical circuits, the input impedance is determined by assuming that the op amp itself draws no current; any current drawn is assumed to be drawn by the remainder of the biasing and feedback circuits. Kirchhoff's voltage law is written for the signal-to-ground circuit.

Depending on the method of feedback, the op amp can be made to perform a number of different operations, some of which are illustrated in Table 1. The gain of an op amp by itself is positive. An op amp with a negative gain is assumed to be connected in such a manner as to achieve negative feedback.

SAMPLE PROBLEMS

4. For the difference amplifier circuit shown, determine the output voltage at terminal A.

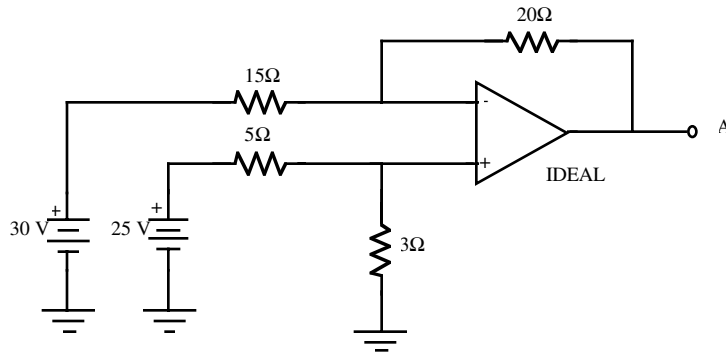

- (A) - 18.13 V
 (B) -6.07 V
 (C) 6.07 V
 (D) 15.45 V

Solution:

By voltage division,

$$v_{in+} = 25V \left(\frac{3\Omega}{5\Omega + 3\Omega} \right) = 9.375V$$

By the virtual short circuit between the input terminals, $v_{in-} = 9.375 V$
 Using **Ohm's** law, the current through the 15Ω resistor is

$$I_{15} = \left(\frac{30V - 9.375V}{15\Omega} \right) = 1.375V$$

The input impedance is infinite; therefore, $I_{in-} = 0$ and $I_{15} = I_{20}$.

Use Kirchoff's voltage law to find the output voltage at A.

$$v_A = v_{in-} - 20I_{20} = 9.375 V - (20\Omega)(1.375 A) = -18.125 V$$

Answer is A.

Problems 2 and 3 refer to the following figure.

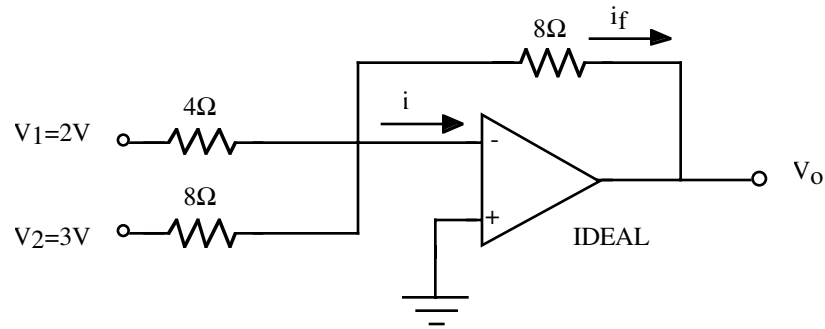

2. What is the current, i ?

- (A) -0.88 A
- (B) -0.25 A
- (C) 0 A
- (D) 0.25 A

Solution 2:

The input current in an op amp is so small that it is assumed to be zero.

Answer is C.

3. What is the output voltage, v_o ?

- (A) -7 V
- (B) -6 V
- (C) -1 V
- (D) 6 V

Solution 3:

This op amp circuit is a summing amplifier. Since $i=0$,

$$i_f = \frac{v_1}{R_1} + \frac{v_2}{R_2} = \frac{3 \text{ V}}{8 \Omega} + \frac{2 \text{ V}}{4 \Omega} = 0.875 \text{ A}$$

$$v_o = -i_f R_f = -(0.875 \text{ A})(8 \Omega) = -7 \text{ V}$$

Answer is A.

4. For the ideal op amp shown, what should be the value of resistor R_f to obtain a gain of 5?

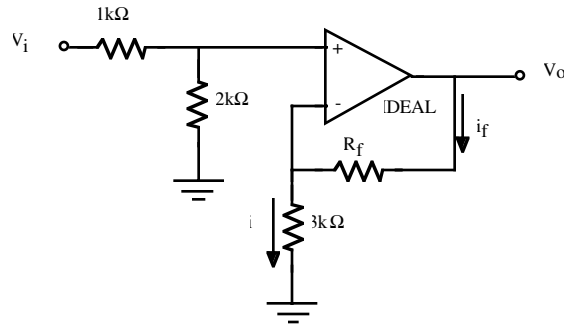

- (A) 12.0 kΩ
- (B) 19.5 kΩ
- (C) 22.5 kΩ
- (D) 27.0 kΩ

Solution:

By voltage division, $v_{in+} = v_i \left(\frac{2k\Omega}{3k\Omega} \right) = \frac{2}{3} v_i$

By the virtual short circuit, $v_{in-} = v_{in+} = \frac{2}{3} v_i$

$$i = \frac{v_{in-}}{3k\Omega} = \frac{\frac{2}{3} v_i}{3k\Omega}$$

Since the op amp draws no current, $i_f = i$

$$\frac{v_o - v_{in-}}{R_f} = \frac{\frac{2}{3} v_i}{3k\Omega}$$

But, $v_o = 5v_i$.

$$\frac{5v_i - \frac{2}{3} v_i}{R_f} = \frac{\frac{2}{3} v_i}{3k\Omega}$$

$$\frac{13}{3} = \frac{2}{3k\Omega} R_f$$

$R_f = 19.5 \text{ k}\Omega$, Answer is B.

5. Evaluate the following amplifier circuit to determine the value of resistor R_4 in order to obtain a voltage gain (v_o/v_i) of -120.

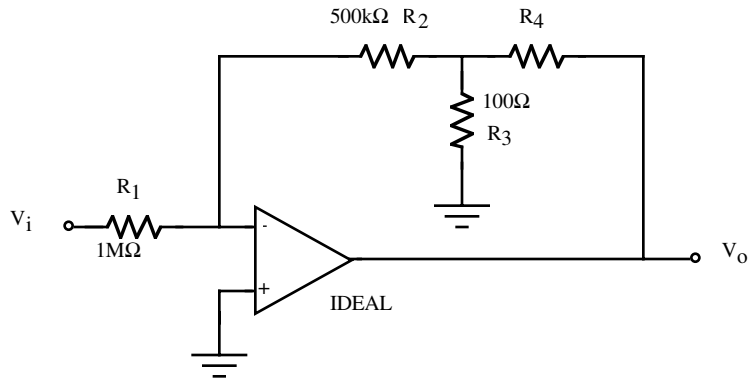

- (A) 25 Ω
- (B) 23 k Ω
- (C) 24 k Ω
- (D) 25 k Ω

Solution:

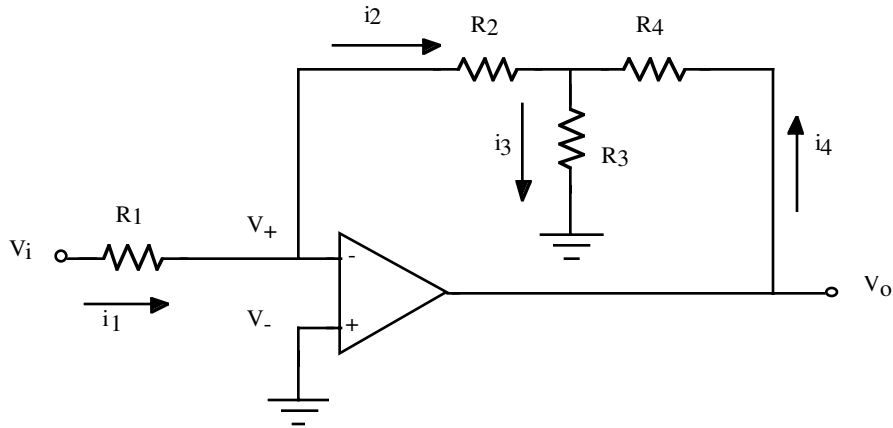

v_{in+} is grounded, so v_{in-} is also a virtual ground.

$$v_{in-} = 0$$

Since $v_{in-} = 0$, $v_i = i_1 R_1$ and $i_1 = v_i / R_1$.

Since $v_{in-} = 0$, $v_x = -i_2 R_2$ and $i_2 = -v_x / R_2$.

Similarly,

$$v_x = -i_3 R_3$$

$$v_x - v_o = -i_4 R_4$$

From Kirchhoff's current law,

$$i_4 = i_2 + i_3$$

$$\frac{v_x - v_o}{R_4} = \frac{-v_x}{R_2} + \frac{-v_x}{R_3}$$

Now, $v_o = -120v_i$.

Also, $i_1 = i_2$, so

$$\frac{v_i}{R_1} = \frac{-v_x}{R_2}$$

$$v_x = -\left(\frac{R_2}{R_1}\right)v_i$$

$$\frac{-\left(\frac{R_2}{R_1}\right)v_i - (-120v_i)}{R_4} = \frac{\left(\frac{R_2}{R_1}\right)v_i}{R_2} + \frac{\left(\frac{R_2}{R_1}\right)v_i}{R_3}$$

$$\frac{120\left(\frac{R_1}{R_2}\right) - 1}{R_4} = \frac{1}{R_2} + \frac{1}{R_3} = \frac{R_2 + R_3}{R_2 R_3}$$

$$R_4 = \frac{120\left(\frac{R_1}{R_2}\right) - 1}{\frac{R_2 + R_3}{R_2 R_3}} = \frac{120\left(\frac{1 \times 10^6 \Omega}{5 \times 10^5 \Omega}\right) - 1}{\frac{5 \times 10^5 \Omega + 100 \Omega}{(5 \times 10^5 \Omega)(100 \Omega)}} = 2.39 \times 10^4 \Omega \text{ (24 k}\Omega\text{)}$$

Answer is C.

13. For the circuit shown below:

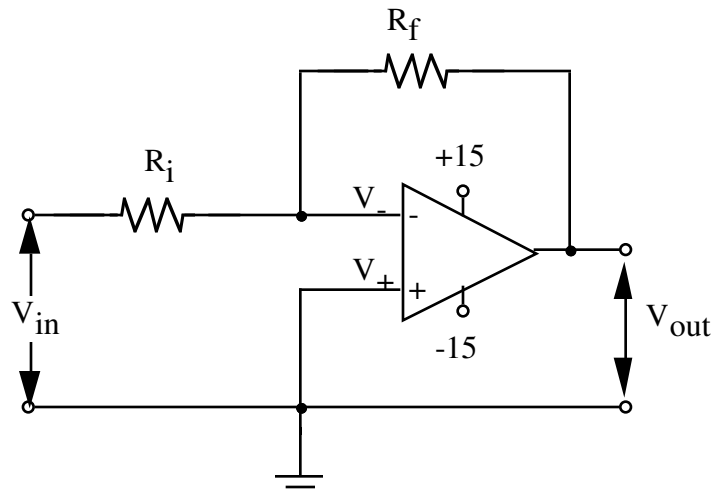

(a) If $R_f = 1M\Omega$ and $R_i = 50\Omega$, what is the voltage gain?

There are two ways to solve any problem involving an op amp. The first way is to use the formulas given in the Reference Handbook. Explicitly, $v_o = -\frac{R_2}{R_1}v_a + \left(1 + \frac{R_2}{R_1}\right)v_b$, where v_a is the input to the inverting terminal and v_b is the input to the non-inverting terminal. In this case, there is no input to the non-inverting input and $v_b = 0$. The formula reduces to the simple result

$v_o = -\frac{R_2}{R_1}v_a$. Using the given circuit values, we get

$v_o = -\frac{R_2}{R_1}v_a = -\frac{R_f}{R_i}v_{in} = -\frac{1M\Omega}{50\Omega}v_{in} = -20,000v_{in}$. The voltage gain is then -20,000. Note that any value over 100 is impractical for any real amplifier.

A more general way of solving any op amp circuit is to note that an ideal (and most real) op amps must satisfy the virtual short assumption, i.e. that $V_+ = V_-$. Using this assumption and KCL at an input node is adequate to solve most any op amp problem. In this case, KCL at the inverting input gives $+\frac{V_{in}}{R_i} - \frac{0 - V_{out}}{R_f} = 0$. Rearranging, $\frac{V_{in}}{R_i} + \frac{V_{out}}{R_f} = 0$ and, solving for the voltage gain,

$$\frac{V_{out}}{V_{in}} = -\frac{R_f}{R_i} = -\frac{10^6}{50} = -20,000 \text{ just as before}$$

(b) If $V_{in} = 0.1$ volts, what is V_{out} ?

This is a continuation of (a). Using our voltage gain from (a) we get

$$v_o = -20,000v_{in} = -20,000(0.1 \text{ volts}) = -2000 \text{ volts}$$

As mentioned previously, this is a ridiculous value for an output.

14. For the circuit shown below, $V_1 = 10\sin(200t)$ and $V_2 = 15\sin(200t)$. What is V_{out} ? The op amp is ideal with infinite gain.

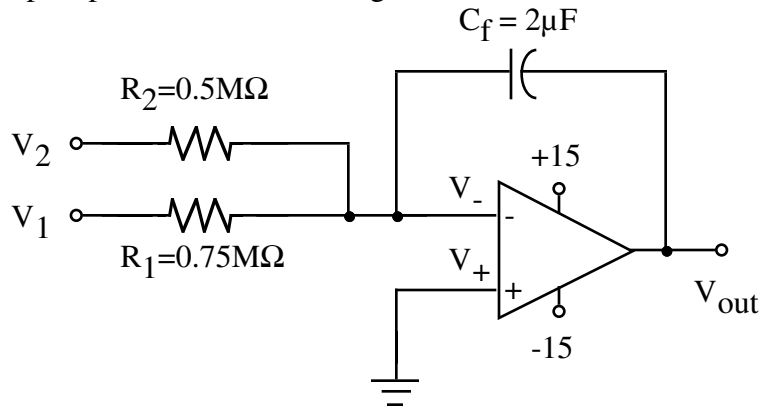

ANSWER:

Any problem with a capacitor (or inductor) in it and sinusoidal voltages immediately indicates that phasors are required. This means that V_1 and V_2 should be represented as phasors, and C_f should be replaced by an impedance. This problem is not solved very well with the formulas in the Reference Handbook. This circuit is most easily solved using the virtual short assumption ($V_+ = V_-$), and using KCL at the inverting input. Note that the grounding of V_+ then requires that $V_- = 0$. This is also called the virtual short assumption.

$$+\frac{V_2 - 0}{R_2} + \frac{V_1 - 0}{R_1} - \frac{0 - V_{out}}{1/j\omega C} = 0.$$

Rationalizing this expression gives $+\frac{V_2}{R_2} + \frac{V_1}{R_1} + j\omega C V_{out} = 0$.

$$\text{Solving for } V_{out} \text{ gives } V_{out} = -\frac{V_2}{j\omega C R_2} - \frac{V_1}{j\omega C R_1}$$

It is important to recognize that all sine functions should always be converted to cosines for proper phase in the phasor expressions, i.e. $\sin(200t) = \cos(200t - 90^\circ) \leftrightarrow 1\angle -90^\circ = -j$

Using the circuit parameters given,

$$\begin{aligned} V_{out} &= \frac{-j15}{j(200)(2 \times 10^{-6})(0.5 \times 10^6)} - \frac{-j10}{j(200)(2 \times 10^{-6})(0.75 \times 10^6)} \\ &= \frac{15}{200} + \frac{10}{300} = \frac{3}{40} + \frac{1}{30} \end{aligned}$$

The answer is then $V_{out}(t) = \left(\frac{3}{40} + \frac{1}{30}\right)\cos(200t)$

Diodes

1. A germanium diode is operated at 20° C. A reverse bias of -1.5 volts results in a current of 70μA. Assuming that the temperature remains constant:

(a) What is the saturation current?

The general formula for the diode is $I = I_s \left(e^{\frac{qV}{\eta kT}} - 1 \right)$. Solving for I_s gives $I_s = \frac{I}{e^{\frac{qV}{\eta kT}} - 1}$. Using

the given parameters and recognizing that $\eta \approx 1$ for a germanium diode, we get

$$I_s = \frac{-70 \mu A}{\frac{(1.6 \times 10^{-19} C)(-1.5 V)}{(1.38 \times 10^{-23} J / 293 K)} - 1} \approx \frac{-70 \mu A}{-1} = +70 \mu A$$

As a point of information this current is essentially constant throughout the reverse bias region of the diode. See the curve below for a typical diode.

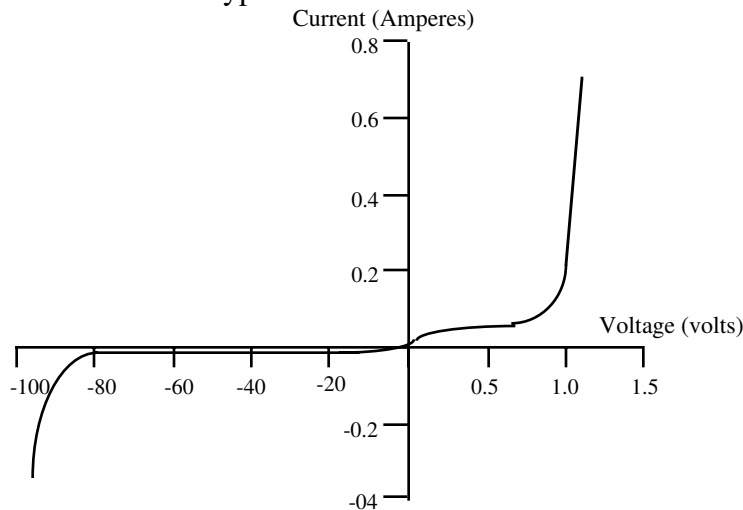

(b) What is the current that flows for a forward bias of +0.2 volts?

We use a commonly known result here to simplify the math, i.e. that, at room temperature, $\frac{q}{kT} \approx 40/\text{volts}$. For this problem, using the I_s from (a),

$$\begin{aligned} I &= I_s \left(e^{\frac{qV}{\eta kT}} - 1 \right) \approx I_s \left(e^{\frac{V(40/\text{volts})}{\eta}} - 1 \right) \\ &= (70 \mu A) \left(e^{\frac{+0.2 \text{ volts}(40/\text{volts})}{(1)}} - 1 \right) = (70 \mu A) (e^{+8} - 1) \approx 0.209 \text{ amperes} \end{aligned}$$

(c) What is the current that flows for a forward bias of +0.2 volts at 40° C?

2. A voltage $V = 20 + 5\sqrt{2}\sin(60t)$ volts is applied to the circuit shown below. The diode characteristics are static forward resistance $r_f=120\Omega$ and dynamic resistance $r_p=100\Omega$. What is the voltage across the inductance?

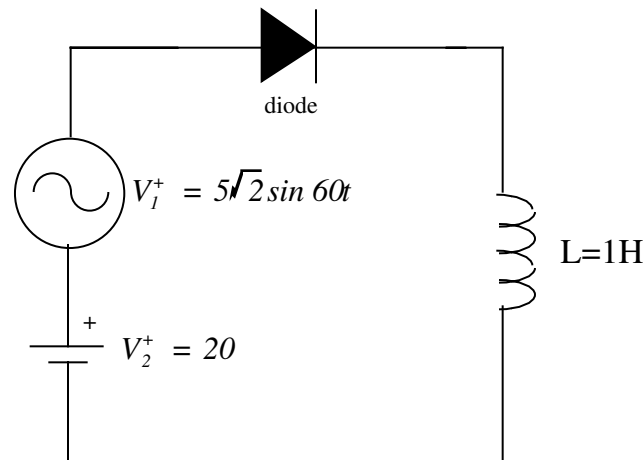

This is a trick question since the V_2^+ voltage (+20 volts) $> V_1^+$ ($\pm 5\sqrt{2}$ volts max.) the diode is always forward biased and always conducting. Therefore, the diode serves no useful purpose. The model for the diode then becomes an ideal diode (which can be ignored) and a 100Ω dynamic resistance.

The circuit becomes that of a voltage divider. We can use superposition to determine the voltage across the inductor. Since the inductor appears as a short to the DC source the contribution from that source is zero. For the AC source we have a reactive voltage divider.

$$\begin{aligned}
 V_L &= \frac{j(60\text{rad/sec})(1)}{j(60\text{rad/sec})(1) + 100\Omega}(-j5\sqrt{2} \text{ volts}) \\
 &= \frac{j60}{j60 + 100}(-j5\sqrt{2} \text{ volts}) = (0.26 + j0.44)(-j5\sqrt{2} \text{ volts}) \\
 &= (+ 3.12 - j1.87) \text{ volts} = 3.64 \angle -31^\circ
 \end{aligned}$$

The total voltage across the inductor is then the sum of the ac and dc voltages or $3.64\angle-31^\circ$ volts.

3. At 25° C a germanium diode shows a saturation current of 100μA.

(a) What current would you expect at 100° C when the diode becomes "useless"?

This is simply formula evaluation. The saturation current doubles every 10° C. Therefore,

$$\frac{I_{s2}}{I_{s1}} = 2^{\frac{\Delta T}{10^\circ C}} = 2^{\frac{100^\circ C - 25^\circ C}{10^\circ C}} = 2^{7.5} = 181. \text{ This gives } I_{s2} = 181 I_{s1} = 181(100\mu A) = 18.1 \text{ mA}$$

(b) What current would you expect at 0° C ?

Using the same approach we have

$$I_{s2} = 2^{\left(\frac{\Delta T}{10^\circ C}\right)} I_{s1} = 2^{\left(\frac{0^\circ C - 25^\circ C}{10^\circ C}\right)} I_{s1} = 2^{-2.5} I_{s1} = 0.177(100\mu A) = 17.7 \mu A$$

(c) At 25° C, what current is predicted for a voltage of -0.5 volts?

This is purely formula evaluation.

$$\begin{aligned} I &= I_s \left(e^{\frac{qV}{\eta kT}} - 1 \right) \approx I_s \left(e^{\frac{V(40/volt)}{\eta}} - 1 \right) \\ &= (100\mu A) \left(e^{\frac{-0.5 \text{ volts}(40)}{1}} - 1 \right) \approx -100 \mu A \end{aligned}$$

4. The forward resistance of the diodes is $R_f=5k\Omega$.

(a) What current is expected in the load resistor $R_L=5k\Omega$ if $V = 100\sin(\omega t)$ volts?

This is nothing but Ohm's Law evaluation. The diode is conducting in the positive half cycle and we use the forward resistance of the diode.

$$I = \frac{100\sin(\omega t)}{5000\Omega + 5000\Omega} = 0.01\sin(\omega t) \text{ volts}$$

(b) Plot current and voltage versus ωt for $0 < \omega t < 2\pi$.

These are pretty simple to generate.

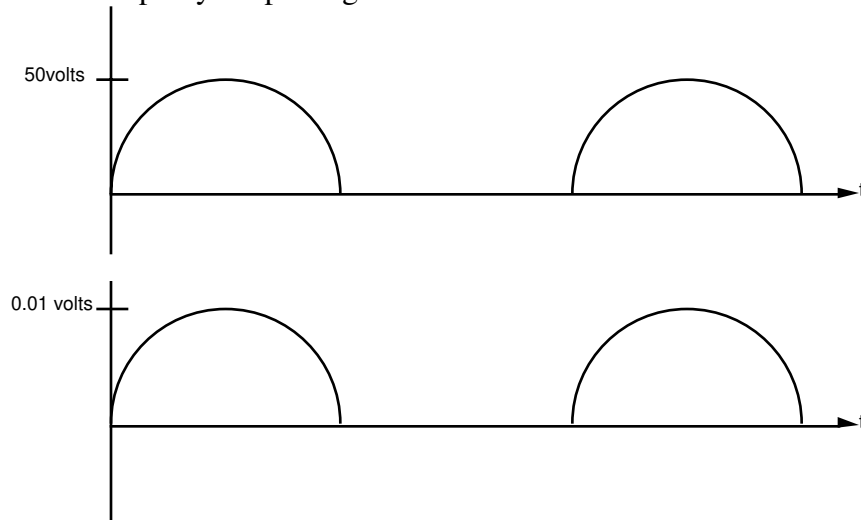

Error! No table of contents entries found.