

Exercise Cygnus

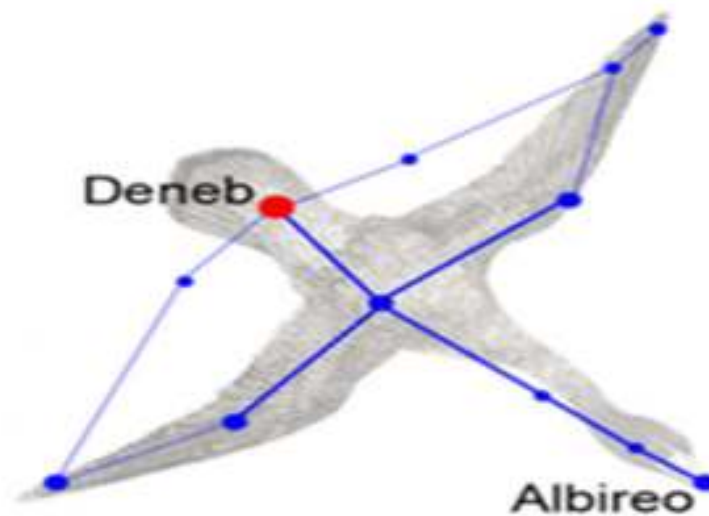

Lincolnshire's Resilience Forum



**PREPARING FOR EMERGENCIES
WHAT YOU NEED TO KNOW**

Influenza Pandemic

- Identified as a tier one risk to the UK
- One of the nine enduring risks to Lincolnshire
- Cabinet Office has requested that the Department of Health lead the delivery of a national pandemic influenza exercise
- Lincolnshire Local Resilience Forum selected to take part

National Aim and Objectives

- **Aim**
 - To assess the preparedness and response to an influenza pandemic in the United Kingdom
- **Objectives**
 - To exercise organisational pandemic influenza at local and national levels in the United Kingdom
 - To exercise coordination of messaging to the public
 - To exercise strategic decision-making processes around managing the wider consequences and cross-government issues at both local and national levels during an influenza pandemic (such as excess deaths)
 - To exercise the provision of scientific advice, including SAGE, during an influenza pandemic

Lincolnshire's Resilience Forum



PREPARING FOR EMERGENCIES
WHAT YOU NEED TO KNOW

Exercise Scope

- Phase one (early stages) - health focused simulating the DH delivery board - 14 May 14
- Phase two - Command-Post Exercise (CPX) w/c 13 Oct 14
- Conducted over 3 days with phased participation to fit with a national battle rhythm
- SCG exercise on the first 2 days
- Telephone point of contact for the final exercise day

Lincolnshire's Resilience Forum



PREPARING FOR EMERGENCIES
WHAT YOU NEED TO KNOW

Scenario

- New strain H2N2 first cases in SE Asia in June / July 14
- CDC identifies the virus as H2N2 and SE Asian countries notifies WHO of cases late July
- First cases in UK from returning travellers August 14
- Cluster of cases from September 14
- WHO declare a pandemic September 14
- UK peak – mid November 14
- 1st UK wave completed by mid to late January 15

Lincolnshire's Resilience Forum



PREPARING FOR EMERGENCIES
WHAT YOU NEED TO KNOW

Visual representation of the possible course of the pandemic wave for exercise Cygnus

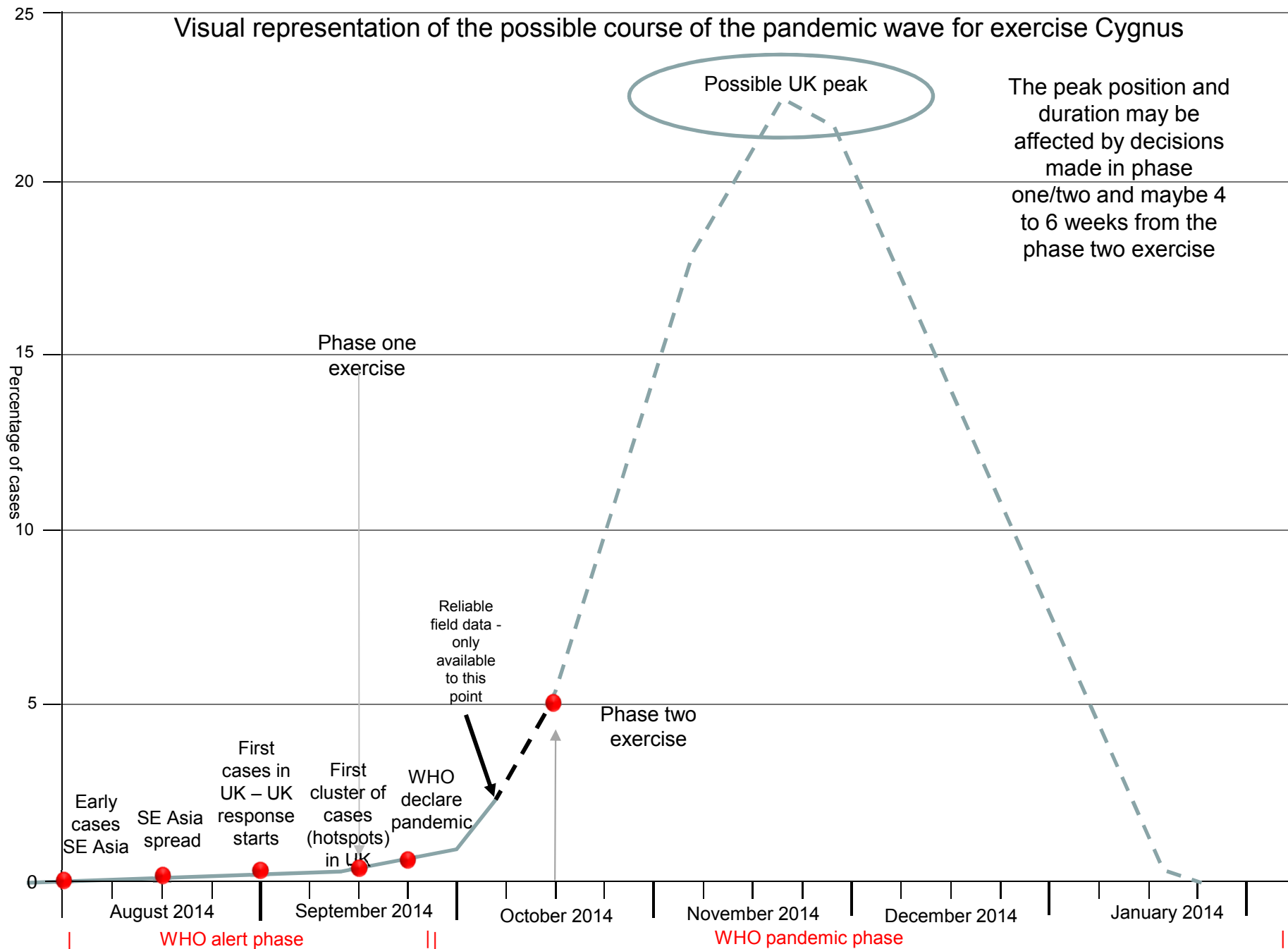

Exercise Cygnus: SCG Participation & Information Flow

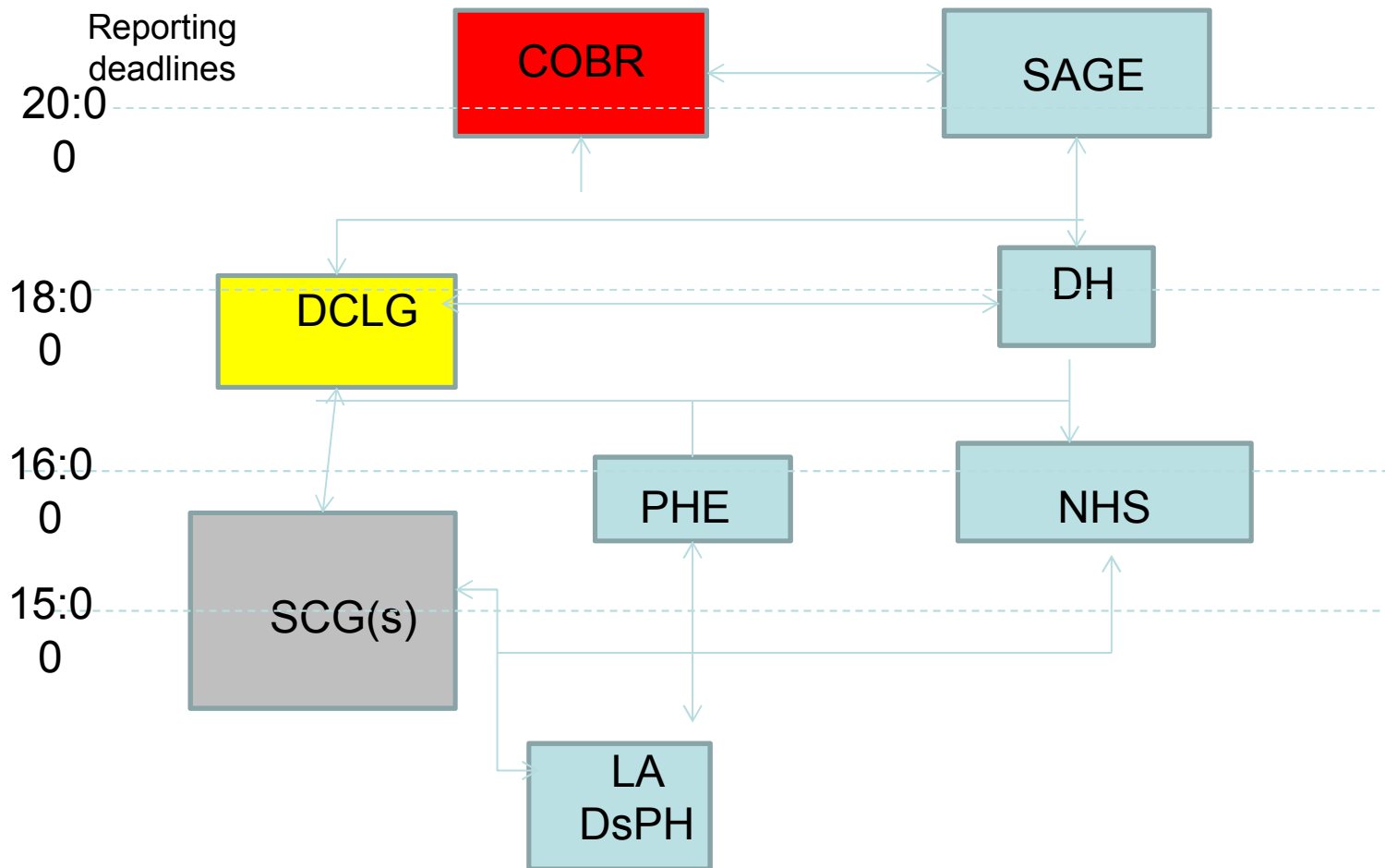

Participant Overview

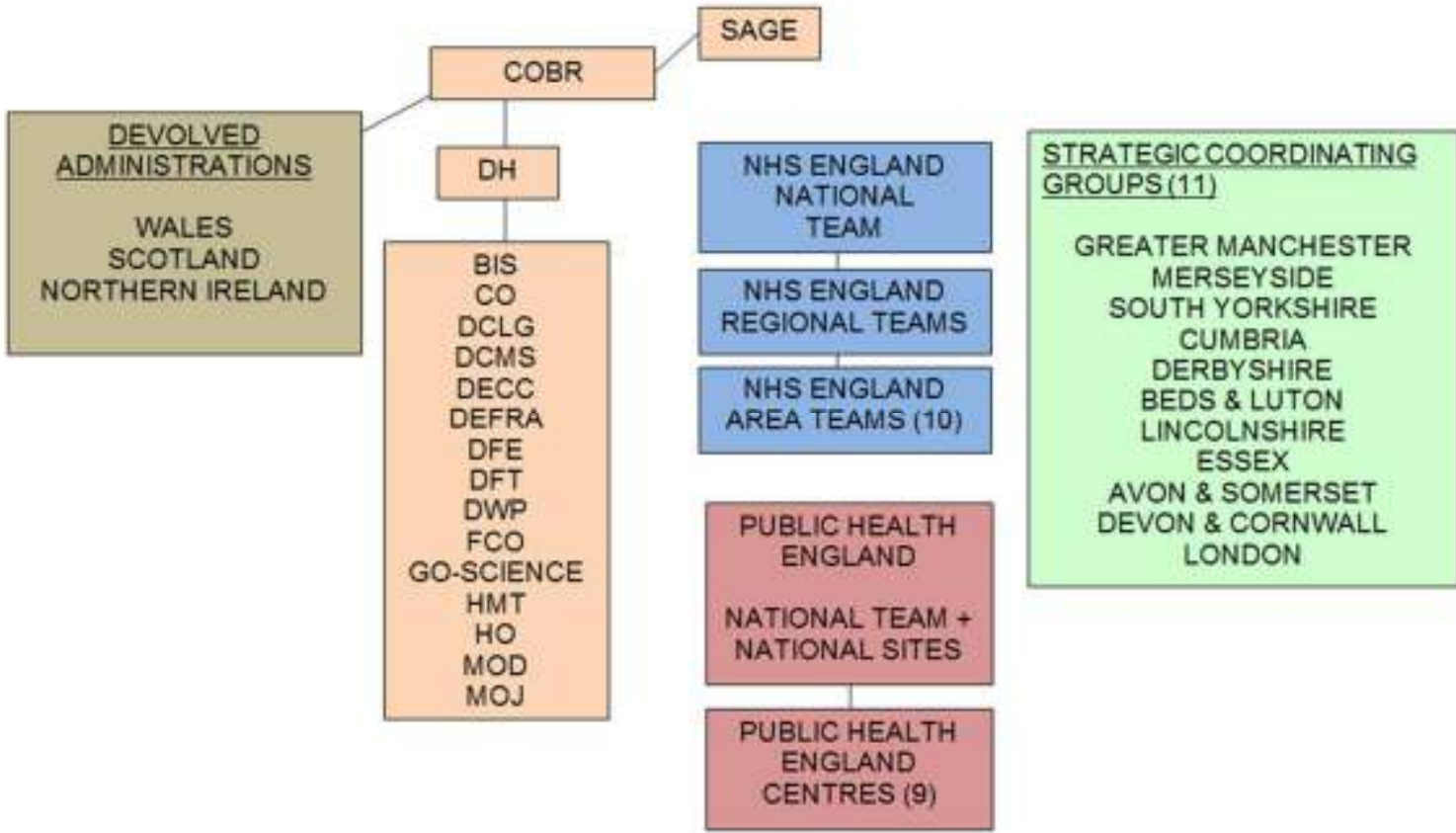

Lincolnshire's Resilience Forum



PREPARING FOR EMERGENCIES
WHAT YOU NEED TO KNOW

Geographical spread

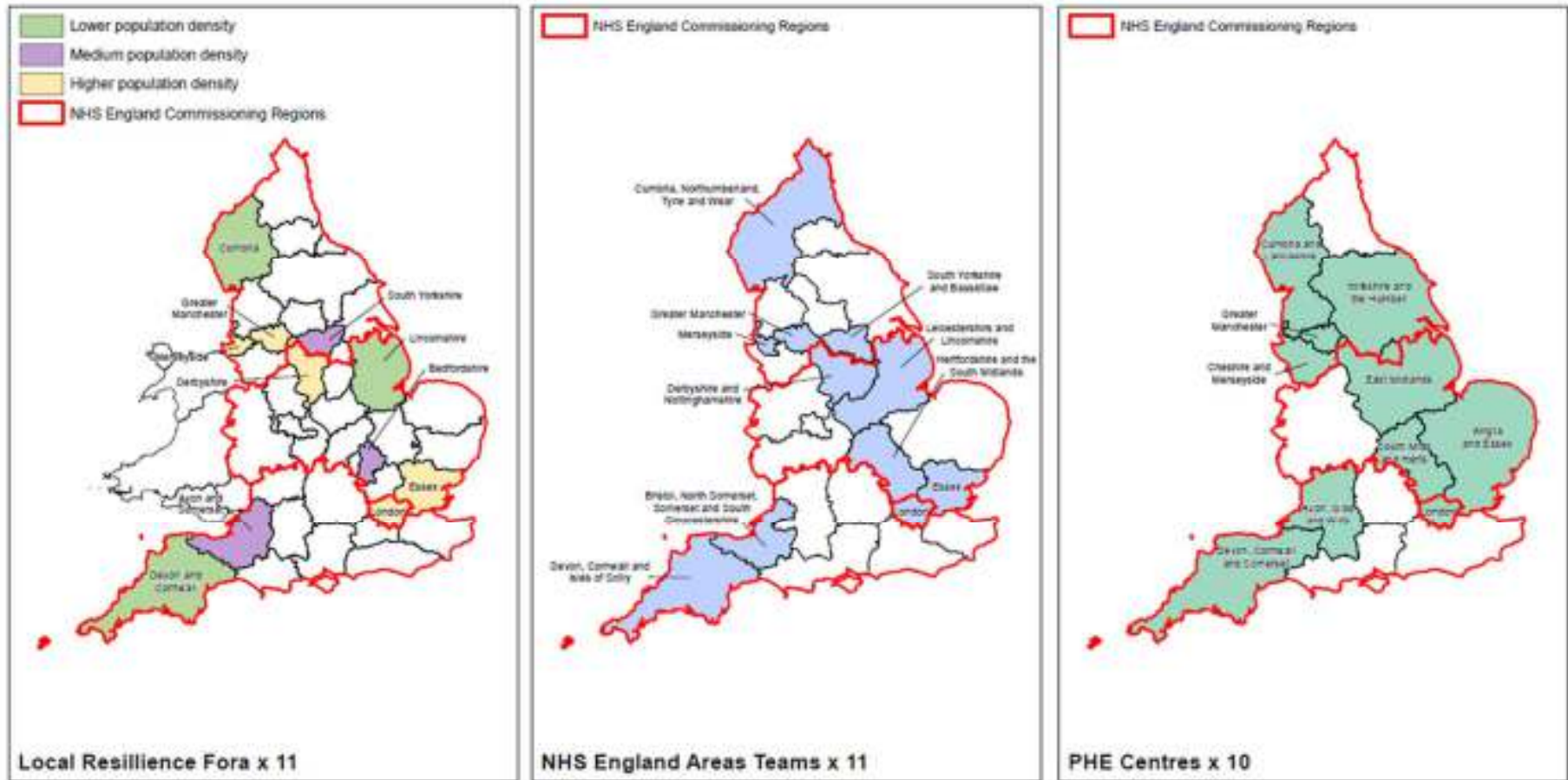

Lincolnshire's Resilience Forum



PREPARING FOR EMERGENCIES
WHAT YOU NEED TO KNOW

Local Strategic Objectives

- Test LRF multi-agency capability and capacity to respond to a severe pandemic outbreak
- Test cat 1&2 responders and voluntary sector business continuity planning to maintain critical functions during a severe pandemic outbreak
- Rehearse key people in strategic and tactical lead responder and multi-agency co-ordination roles
- Engage with health, social care and education providers in considering the impacts of resilience and preparedness for a severe pandemic outbreak
- Test partnership communications processes (with an emphasis on learning from recent exercises and emergency responses)

Lincolnshire's Resilience Forum



PREPARING FOR EMERGENCIES
WHAT YOU NEED TO KNOW

Exercise Cygnus

- Brief the Members of the Health Scrutiny Committee for Lincolnshire on Exercise Cygnus
- To explain the Exercise design
- Opportunity for you to observe the Exercise
- Key learning resulting from the Exercise will be shared with the committee

